

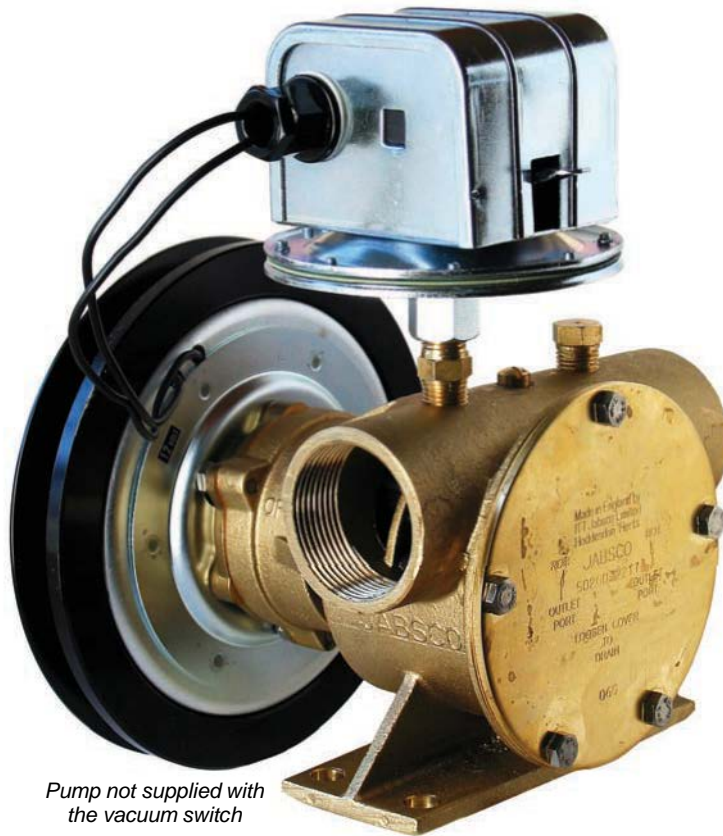

Installation, Operating,
Maintenance and Safety Instructions
JABSCO 4732-0000
VACUUM SWITCH



*Pump not supplied with
the vacuum switch*

**TO OBTAIN THE BEST PERFORMANCE FROM YOUR JABSCO
VACUUM SWITCH PLEASE READ THESE INSTRUCTIONS CAREFULLY**

*Failure to observe the recommended procedures may result in early
and severe damage to your equipment, and may invalidate the
supplier's guarantee*

Doc593/12

- ✦ Protects flexible impeller pumps from dry running damage
- ✦ Manual start, automatic stop - remote start possible
- ✦ Requires minimum 1.2m suction lift

GENERAL INFORMATION

The vacuum switch is an electrical device wired into the power circuit to an electric motor, or electric clutch. The switch is mounted on the inlet side of the pump, between the pump and the liquid source; it senses the break in vacuum when the pump runs out of liquid. The break in vacuum causes the switch to open the circuit and shut-off the motor or deactivate the clutch. The switch contains a spring loaded diaphragm sensitive to a vacuum of not less than 2-1/2" Hg (mercury).

The vacuum switch is generally installed in a pumping system when transferring or pumping a limited amount of liquid, when the pump cannot be attended at all times. The switch provides automatic shut-off when the pump runs dry, helping to prevent damage to the pump. Normally, the switch is manually restarted, although it is possible with electric motor and clutch installations to wire a momentary switch, float, or liquid level device across the terminals of the vacuum switch to reactivate the system remotely or automatically.

The switch case and diaphragm enclosure are cad-plated or enamel-coated steel and could be subject to corrosive attack from chemicals or chemical fumes. The diaphragm is neoprene.

If a vacuum switch is used with a pump handling corrosive fluids, the switch life may be extended by mounting the switch remotely and connecting the switch to the pump with stainless steel tubing or hard plastic tubing. All connections must be AIRTIGHT and non-collapsible.

TYPICAL INSTALLATIONS

For pump models furnished with 1/4" pipe tap in suction port, as shown on the larger front cover photograph.

1. Remove pipe plug from port.
2. Place a small amount of sealing compound or TFE tape on the nipple threads; screw into tapped hole in the switch and pump port until the nipple is securely sealed. Use the hex nut on the switch for tightening.
3. Remove the single screw and take off the cover.
4. Follow the wiring diagram applicable to system being used, connect wiring, and replace cover. (Fig 1)
5. To operate, hold down the restart lever until the pump holds its prime, release the lever and the pump will continue until the liquid source is depleted or the power disconnected.

For models not furnished with pipe tap in suction port. (Fig 2)

1. Using sealing compound or TFE tape install a pipe tee to pump inlet port
2. Install reducer bushing in branch of pipe tee if required. Use 1/4" short nipple for vacuum switch connection
3. Proceed with installation of switch according to instruction 3 - 5 above

For remote installations, to protect the switch from corrosive fluids or food product contamination (Fig 3)

1. Install the tube fitting in tapped hole in suction port or tee port fitting
2. Use non-collapsible plastic or metal tubing to connect the tube fitting to the vacuum switch. Locate above the pump

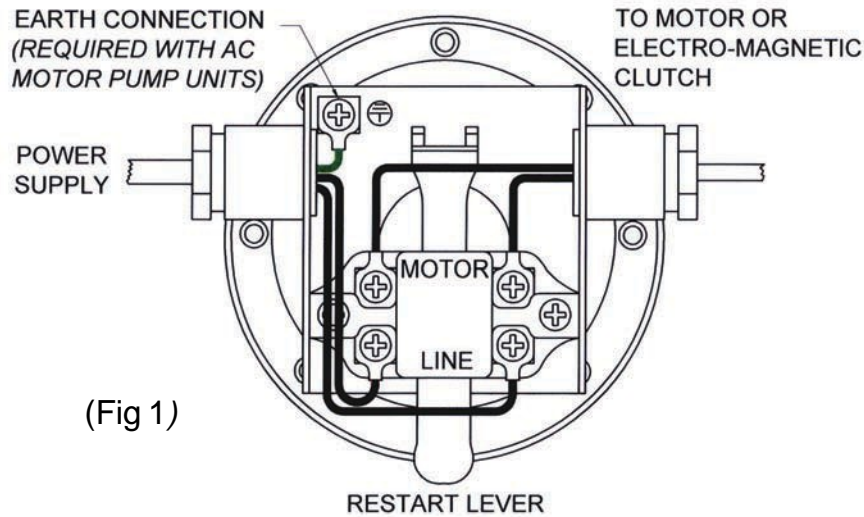

WIRING DIAGRAMS

MANUAL START

ELECTRIC MOTOR AND CLUTCH UNITS

SWITCH RATINGS	
Max Voltage 250v	
POWER SUPPLY	POWER
1 phase 110v ac	1.5Kw
1 phase 220v ac	2.2Kw
12/24/32v dc	0.37Kw
12/24v dc clutch	10amps max

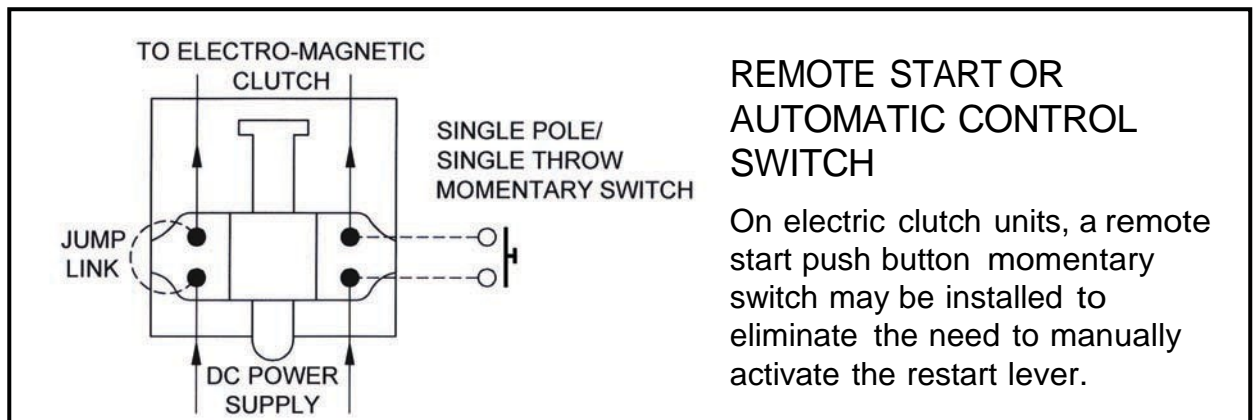

SERVICE TIPS – SPECIAL ATTENTION

- Constant vibration of the starting handle indicates
 - An air leak. This will usually show up when the pump is first started. Check all suction line for leaks. Make sure all threaded joints are sealed with a sealing compound
 - A worn impeller. Replace impeller and check for wear on the cam, cover and wear plate
- Intermittent stopping and starting indicates the unit is operating against excessive discharge pressure.
- Remote switch location will extend life of switch when pumping corrosive liquids
- Do not jam starting lever in down position or the switch will not function as designed

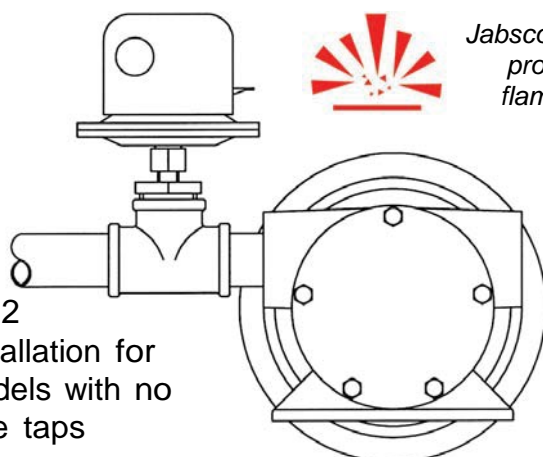

WARNING

Jabsco Vacuum Switch is not ignition protected, do not install where flammable vapours are present

Fig 3
Remote installation to protect the switch from corrosive liquids or food contamination

